

Digital clock «Opalys Ellipse»

For Indoor



Description

- Indoor clock with backlit liquid crystal display (LCD)
- Hour and multilingual date display, with temperature
- Extra flat casing
- Optimal viewing distance 25 metres (Height of digits 5 cm), angle of vision 160°
- Integrated temperature probe
- Casing colour: aluminium
- Versions: independent quartz, radio synchronised DCF, DHF receiver, impulse slave movement, IRIG B/AFNOR coded time receiver or NTP receiver

Standards

- NF EN 50081-1
- NF EN 50082-1
- NF EN 60950

General features

Eco function	Providing energy savings through switching off display between 23:00 and 06:00
Operation	Silent
Display mode	12 or 24 h
Temperature display	-25°C to +70°C or -13°F to +158°F. Selection °C or °F in the menu. Display resolution: 1°C. Accuracy: ±0.5°C. Offset adjustment, possible from -9.5° to +9.5° in 0.5° steps
Display	Multifunctional
Display of language	A choice of 12 languages
Time change	Pre-programmed automatic summer / winter time changeover and perpetual calendar with multi time zones
Data saving	Permanent
Accuracy of the time quartz base	0.2 second/day (adjustable)
Absolute time accuracy	With optional radio synchronisation
2 Buttons	Programming and time setting
NTP Synchronisation	Unicast, multicast or DHCP server

Mechanical features

Construction	ABS casing, IP40, IK02
Window	Glass
Operating temp. range	-5°C to +50° C
Humidity	80% at 40° C
Weight	1.4 kg

Electrical features

Power supply	- Models: AFNOR coded time receiver, wireless DHF, independent / 24 V minute impulse receiver: 230 VAC ±10 %, 50 / 60 Hz - Model NTP: PoE (Power Over Ethernet)
Consumption	Models AFNOR, DHF, DCF: 0.3 A (Class II) Model NTP: 6 W (Class III PoE)

Ordering information

938 324A	Radio synchronised DCF
938 333A	Slave movement on impulses or IRIG B/AFNOR receiver
938 342A	DHF radio receiver
938 372A	NTP PoE receiver
Accessories:	
202 271	Wall support (supplied)
938 902	Table support
938 901	Double sided bracket for wall or ceiling mounting
938 905	Double sided bracket for wall or ceiling mounting (long length)
938 908	Single or double sided bracket specific length for wall or ceiling mounting. Please specify on the order the fixing mode (wall or ceiling) and the length between the top of the clock and the fixing point

Multifunctional clock

Possibility for fixed or alternate display on the bottom display line:

- Multilingual date
- Numerical date
- Indoor ambient temperature
- Day number (Julian) and week number
- Second counter
- Site or city or company name or message (up to 7 characters)

Movements and synchronisation

Quartz movement

The clock is totally independent, the time information comes from its own time basis. Automatic summer/winter time changeover.

DHF movement

The clock is radio-synchronised by a DHF transmitter. Automatic summer/winter time changeover.

DCF Radio synchronised movement

The clock is independent, the time information comes from its own time basis which is rectified, in case of drift, by comparing it to the DCF transmitter signal. The radio synchronisation permit to display the time with perfect accuracy. Automatic summer/winter time changeover.

IRIG B/AFNOR coded time receiver

The coded time distribution consist in transmitting a complete time message each second: the setting on time of the receivers is realised automatically and speedily as soon as they are connected on the clock line. The IRIG B/AFNOR coded time does not transmit interference and is insensitive to other electrical interference.

24 V minute impulses receiver movement

The receiver clocks are connected to a distribution line and activated by means of electrical impulses transmitted every minute by the master clock.

NTP PoE receiver

The slave clocks are connected to the network Ethernet through IP addressing. The time synchronisation is distributed from primary servers towards the network or master clock with unicast, multicast or by DHCP models. The NTP server must have a transmission (Poll) period of less than 128 seconds.

Dimensions (in mm)

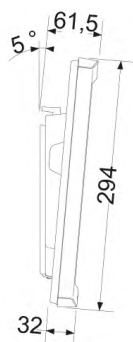
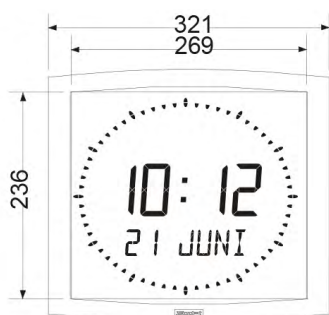

Double-sided bracket